

LawnMaster[®]

Operator's Manual

24V MAX* Lithium-ion Cordless Blower CLBL2406

Save this manual for future reference

* Maximum initial battery workload voltage (measured without a workload) is 24 volts.

Nominal voltage is 21.6 volts.

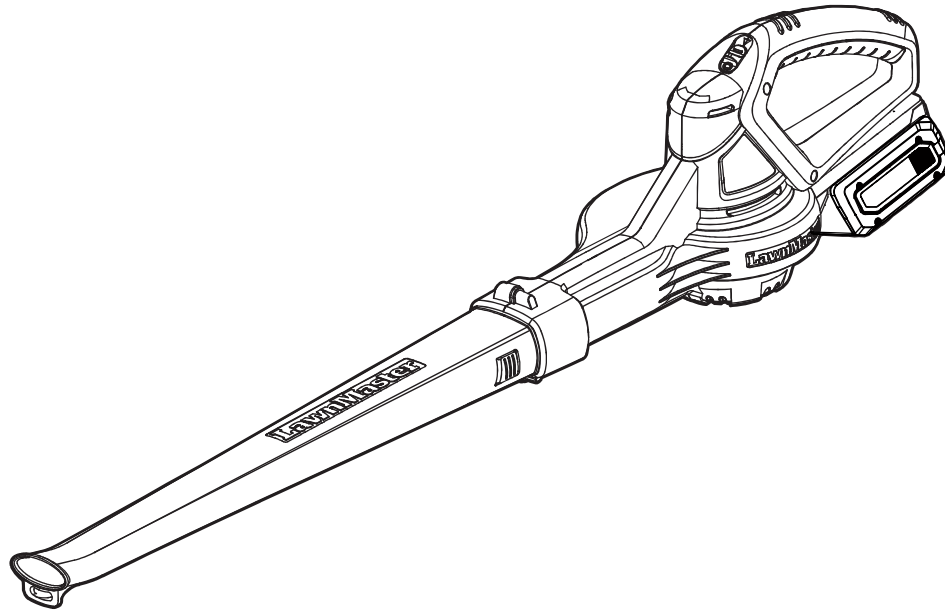

Battery Model Number is 24LB4005-CN

Charger Model Number is 24LFC14-ETL



Read all safety rules and instructions carefully before operating this tool.

Distributed By: Suzhou Cleva Electric Appliance Co., Ltd.

NO.8 Ting Rong Street 215122 Suzhou - China

TABLE OF CONTENTS

Section	Page
TABLE OF CONTENTS	2
SPECIFICATIONS	3
IMPORTANT SAFETY INSTRUCTIONS	4-7
SYMBOLS	8-9
KNOW YOUR BLOWER	10-11
ASSEMBLY	12-14
BATTERY PACK AND CHARGER	15-17
OPERATION	18
MAINTENANCE	19-20
ENVIRONMENTALLY SAFE BATTERY DISPOSAL	21
TROUBLESHOOTING	22
LAWNMASTER® WARRANTY	23
EXPLODED VIEW	24
PARTS LIST	25
NOTES	26

SPECIFICATIONS

24V MAX* CORDLESS BLOWER

Type	Cordless, Battery-powered
Max Air Volume	135 CFM
Max Air Speed	135 MPH
Weight with Battery	2.43 lbs (1.10 kg)

BATTERY PACK

Model Number	24LB4005-CN
Rated Voltage of Battery	24 V Max* D.C
Capacity of Battery	4.0 Ah
Battery Type	Lithium-ion

BATTERY CHARGER

Model Number	24LFC14-ETL
Charger Input	120 V ~ 60 Hz 70 W
Charger Output	24 V D.C. 2.5 A
Charging Time	100 minutes (For 24LB4005-CN)

* Maximum initial battery workload voltage (measured without a workload) is 24 volts.
Nominal voltage is 21.6 volts.

IMPORTANT SAFETY INSTRUCTIONS

WARNING

READ AND UNDERSTAND ALL INSTRUCTIONS.

Failure to follow all instructions listed below may result in electric shock, fire and/or serious personal injury:

- Know your blower. Read the Operator's Manual carefully. Learn its applications and limitations, as well as the specific potential hazards related to this blower. Following this rule will reduce the risk of electric shock, fire, or serious injury.
- Do not leave the blower unattended when turned on.
- Do not allow the blower to be used as a toy. Close attention is necessary when used near children.
- Use only as described in this manual. Use only manufacturer's recommended attachments. Accessories that may be suitable for one blower may create a risk of injury when used with another blower.
- If the blower is not working as it should, has been dropped, damaged, left outdoors, or dropped into water, do not try to operate and take it to a service center.
- Do not handle the battery or blower with wet hands.
- Do not put any object into openings. Do not use if any of the openings are blocked; keep free of dust, lint, hair, and anything that may reduce air flow.
- Keep hair, loose clothing, jewelry, fingers, and all parts of body away from openings and moving parts.
- Turn off all controls before removing battery.
- Use extra care when cleaning whilst going up or down steps or walking on uneven surfaces.
- Do not use the blower to blow flammable or combustible liquids, such as gasoline, or use in areas where they may be present.
- Do not use the blower for any job except that for which it is intended.
- Do not force the blower. It will do the job better and with less likelihood of a risk of injury at the rate for which it was designed.
- Keep children away. All persons apart from the operator should be kept at a distance from work area.
- Stay alert and pay close attention to the task when you are operating the blower. Do not operate blower when you are tired.
- Use safety glasses. Always use face or dust mask if operation is dusty.
- Avoid using the blower in a dangerous environment. Do not use the tool in damp or wet locations. Do not use in rain.
- Do not overreach; keep proper footing and balance at all times.
- Maintain the blower with care. Follow instructions for lubricating and changing accessories.
- Check for damaged parts. Before further use of the blower and its accessories, damaged parts, should be carefully checked to determine that it will operate properly and perform its intended function. Check for alignment of moving parts, binding of moving parts, breakage of parts, mounting, and any other condition that may affect its operation. Any part that is damaged should be properly repaired or replaced by an authorized service center unless indicated elsewhere in this manual.
- When not in use, blowers should be stored indoors in a dry, and high or locked-up place, out of reach of children.
- Prevent unintentional starting. Ensure the switch is in the 'Off' position before connecting to battery

IMPORTANT SAFETY INSTRUCTIONS

pack, picking up or carrying the blower. Carrying the blower with your finger on the switch invites accidents.

- Disconnect the battery pack from the blower before making any adjustments, changing accessories, or storing blower. Such preventive safety measures reduce the risk of starting the blower accidentally.
- Keep your work area well lit. Cluttered or dark work areas invite accidents.
- Always wear eye protection, Dust mask, non-skid safety shoes, hard hat, or hearing protection must be used for appropriate conditions.
- Do not use on a ladder, rooftop, tree, or other unstable support. Stable footing on a solid surface enables better control of the blower in unexpected situations.
- Do not use blower if switch does not turn it on or off. A blower that cannot be controlled with the switch is dangerous and must be repaired.
- For residential use only.
- Remove or disconnect battery before servicing, cleaning or removing material from the tool. Such preventive safety measures reduce the risk of starting the blower accidentally.
- Check for misalignment or binding of moving parts, breakage of parts, and any other condition that may affect the blower's operation. If damaged, have the blower serviced before using. Many accidents are caused by poorly maintained blowers.
- Keep the blower and its handle dry, clean, and free from oil and grease. Always use a clean cloth when cleaning. Never use brake fluids, gasoline, petroleum-based products, or any strong solvents to clean your blower. Following this rule will reduce the risk of loss of control and deterioration of the enclosure plastic.
- Do not operate the equipment while barefoot or when wearing sandals or similar lightweight footwear. Wear protective footwear that will protect your feet and improve footing on slippery surfaces.
- Check the work area before each use. Remove all objects such as rocks, broken glass, nails, wire, or string which can be thrown or become entangled in the machine.
- Do not point the blower in the direction of people or pets.
- Never run the unit without the proper equipment attached. Always ensure the blower tubes are installed.
- Do not store outside or in vehicles.
- Do not incinerate this blower even if it is severely damaged. The battery can explode in a fire.
- Blower service must be performed only by a qualified repair technician. Service or maintenance performed by unqualified personnel may result in a risk of injury.
- When servicing a blower, use only identical replacement parts mentioned in the Operators' Manual. Follow instructions in the Maintenance section of this manual. Use of unauthorized parts or failure to follow Maintenance Instructions may create a risk of shock or injury.
- This cordless battery-powered blower does not have to be plugged into an electrical outlet; therefore, it is always in operating condition when the battery is installed. Beware of possible hazards when handling your blower whilst it is switched off or when changing accessories. This will reduce the risk of electric shock, fire, or serious personal injury.
- Never use a blower near fire or hot ashes. Using the blower near fire or ash can spread fires and result in serious injury and/or property damage.
- Never use the blower to spread chemicals, fertilizers, or any other toxic substances. Spreading these substances could result in serious injury to the operator or bystanders.
- Never place the blower on any surface, except a hard, clean surface when the motor is running. Gravel, sand, and other debris can be picked up by the air inlet and thrown at the operator or bystanders, causing possible serious injuries.

IMPORTANT SAFETY INSTRUCTIONS

- This blower is only compatible with LawnMaster® 24LB4005-CN, 24LB4005-C, 24LB1304, 24LB2004, 24LB2605, or 24LB4005 lithium-ion batteries.

BATTERY PACK

- The battery pack is only compatible with LawnMaster® 24LFC14-ETL, 24LFC02-ETL or 24LSC01-ETL chargers.
- Recharge only with the charger specified by the manufacturer and listed in this manual. A charger that is suitable for one type of battery pack may create a risk of fire when used with another battery pack.
- Do not charge battery in a damp or wet location. Following this rule will reduce the risk of electric shock.
- Do not place battery powered blowers or their batteries near fire or heat. This will reduce the risk of explosion and possibly injury.
- Do not open or mutilate the battery. Released electrolyte is corrosive and may cause damage to the eyes or skin. It may be toxic if swallowed.
- Do not dispose of battery packs in fire. They will explode or leak and cause injury. Liquid ejected from the battery may cause irritation or burns.
- Do not crush, drop or damage the battery pack. Do not use a battery pack or charger that has been dropped or received a sharp blow. A damaged battery is subject to explosion. Properly dispose of a dropped or damaged battery immediately.
- Batteries can explode in the presence of a source of ignition, such as a pilot light. To reduce the risk of serious personal injury, never use any cordless product in the presence of open flame. An exploded battery can propel debris and chemicals. If exposed, flush with water immediately.
- Under extreme usage or temperature conditions, battery leakage may occur. If liquid comes in contact with your skin, wash immediately with soap and water. If liquid gets into your eyes, flush them with clean water for at least 10 minutes, then seek immediate medical attention. Following this rule will reduce the risk of serious personal injury.
- When the battery pack is not in use, keep it away from other metal objects, like paper clips, coins, keys, nails, screws, or other small metal objects, that can make a connection from one terminal to another. Shorting the battery terminals together may cause burns or a fire.
- Do not expose a battery pack or blower to fire or excessive temperature. Exposure to fire or temperature above 265°F (130°C) may cause an explosion.
- Do not modify or attempt to repair the blower or the battery pack (as applicable) except as indicated in the instructions for use and care.
- Follow all charging instructions and do not charge the battery pack or blower outside of the temperature range specified in the instructions. Charging improperly or at temperatures outside of the specified range may damage the battery and increase the risk of fire.
- All tool services should be performed by a qualified repair technician using only identical replacement parts. This will ensure that the safety of the product is maintained.

BATTERY CHARGER

- This charger is only compatible with LawnMaster® 24LB4005-CN, 24LB4005-C, 24LB1304, 24LB2004, 24LB2605 lithium-ion batteries.
- To reduce the risk of injury, charge only the specified lithium-ion rechargeable batteries. Other types of batteries may burst, causing personal injury or damage.
- Keep cord and charger away from heat to prevent damage to housing or internal parts.

IMPORTANT SAFETY INSTRUCTIONS

- Do not operate charger with a damaged cord or plug, which could cause shorting and electric shock. If damaged, immediately discontinue use. Replace the charger with the identical unit as listed in the Parts List of this manual.
- Do not use a charger that has been dropped or received a sharp blow.
- Do not disassemble charger. Take it to a qualified service center for check or replacement. Incorrect reassembly may result in a risk of electric shock or fire.
- Do not abuse the charger cord. Never use the cord for carrying, pulling or unplugging.
- Keep cord away from heat, oil, sharp edges or moving parts. Damaged or entangled cords increase the risk of electric shock. If the charger cord is damaged, replace the charger with an identical model as listed in this manual.
- A charger that is suitable for one type of battery pack may create a risk of fire when used with another battery pack.
- Charge the battery at the normal charging temperature between 40°F (4°C) and 100°F (38°C).

FCC COMPLIANCE

- This device complies with Part 15 of the FCC Rules. Operation is subject to the following two conditions:
 - This device may not cause harmful interference, and
 - This device must accept any interference received, including interference that may cause undesired operation.

NOTE: This equipment has been tested and found to comply with the limits for a Class B digital device, pursuant to Part 15 of the FCC Rules. These limits are designed to provide reasonable protection against harmful interference in a residential installation.











- This equipment generates, uses and can radiate radio frequency energy and, if not installed and used in accordance with the instructions, may cause harmful interference to radio communications. However, there is no guarantee that interference will not occur in a particular installation. If this equipment does cause harmful interference to radio or television reception, which can be determined by turning the equipment off and on, the user is encouraged to try to correct the interference by one or more of the following measures:
 - Reorient or relocate the receiving antenna.
 - Increase the separation between the equipment and receiver.
 - Connect the equipment into an outlet on a circuit different from that of the receiver.
 - Consult the dealer or an experienced radio/ TV technician for help.

SAVE THESE INSTRUCTIONS



Refer to them frequently and use them to instruct others who may use this tool. If you loan someone this tool, loan them these instructions also.

SYMBOLS



Some of the following symbols may be used on this product. Please study them and learn their meaning. Proper interpretation of these symbols will allow you to operate the product better and safer.

SYMBOL	NAME	DESIGNATION/EXPLANATION
V	Volts	Voltage
A	Amperes	Current
Hz	Hertz	Frequency(cycles per second)
W	Watt	Power
hrs	Hours	Time
/min	Per Minute	Revolution, strokes, surface speed, orbits etc, per minute
~	Alternating Current	Type of current
≡	Direct Current	Type or a characteristic of current
	Lithium-Ion Battery Recycling	Designates that this tool is in compliance with Lithium-Ion battery recycling program requirements.
	Safety Alert	Indicates a potential personal injury hazard.
	Read The Operator's Manual	To reduce the risk of injury user must read and understand Operator's Manual before using this product.
	Eye and Hearing Protection	Always wear eye protection with side shields marked to comply with ANSI Z87.1, along with hearing protection.
	Wet Conditions Alert	Do not expose to rain or use in damp locations.
	Keep Bystanders Away	Keep all bystanders at least 50ft. away.
	Long Hair	Failure to keep long hair away from the air inlet could result in personal injury.
	Blower Tubes	Do not operate without tubes in place.
	Loose Clothing	Failure to keep loose clothing from being drawn into air intake could result in personal injury.
	Keep Away From Water	Do not dispose of battery packs in rivers or immerse in water.
	Keep Away From Fire	Do not dispose of battery packs in fire. They will explode or leak and cause injury.

SYMBOLS

SYMBOL	NAME	DESIGNATION/EXPLANATION
	Heat Alert	Do not expose battery packs to heat in excess of 140°F (60°C).
	Recycle Symbol	This product uses lithium-ion batteries. Local, state, or federal laws may prohibit disposal of batteries in ordinary trash. Consult your local waste authority for information regarding available recycling and/or disposal options.

The following signal words and meanings are intended to explain the levels of risk associated with this product.

SYMBOL	SIGNAL	MEANING
	DANGER	Indicates an imminently hazardous situation, which, if not avoided, will result in death or serious injury.
	WARNING	Indicates a potentially hazardous situation, which, if not avoided, could result in death or serious injury.
	CAUTION	Indicates a potentially hazardous situation, which, if not avoided, may result in minor or moderate injury.
	NOTICE	(Without Safety Alert Symbol) Indicates a situation that may result in property damage.

SERVICE

Service requires extreme care and knowledge and should be performed only by a qualified service technician. When servicing, use only identical replacement parts.

For troubleshooting or replacement, please call Customer Service for assistance (Toll free number 866-384-8432).

WARNING

To avoid serious personal injury, do not attempt to use this product until you read thoroughly and understand completely the Operator's Manual.

If you don't understand the warnings and instructions in the Operator's Manual, do not use this product. Call Customer Service for assistance (Toll free number 866-384-8432).

KNOW YOUR BLOWER

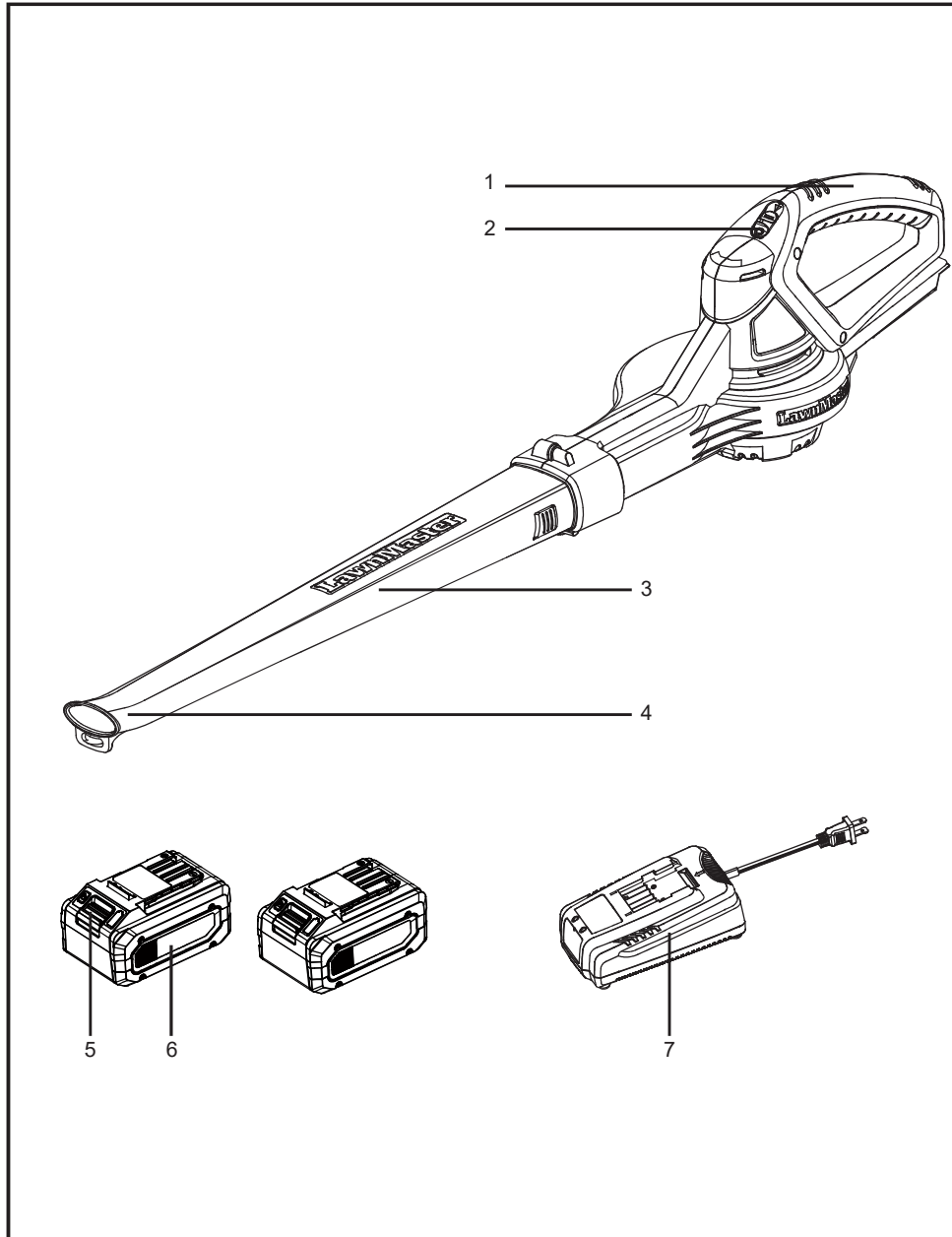

KNOW YOUR BLOWER

Components

1. Handle
2. Power Switch
3. Blower Tube
4. High Velocity Tip
5. Battery Release Button
6. Battery Pack (X2)
7. Battery Charger

KNOW YOUR BLOWER

The safe use of this product requires an understanding of the information on the product labeling and in this Operator's Manual as well as the knowledge of the project you are attempting. Before use of this product, familiarize yourself with all operating features and safety rules.

CORDLESS BLOWER

This cordless blower has a lightweight design that is great for reducing user fatigue in extended use.

BLOWER TUBE

The blower tube can be installed on the blower without using any tools.

ASSEMBLY

UNPACKING

This product requires assembly.

- Carefully remove the product and any accessories from the box. Make sure that all items listed in the packing list are included.
- Inspect the product carefully to make sure no breakage or damage occurred during shipping.
- Do not discard the packing material until you have carefully inspected and satisfactorily operated the product.
- If any parts are damaged or missing, please call Customer Service (Toll free number 866-384-8432).

PACKING LIST

- (1) Blower
- (1) Blower Tube
- (2) 24V 4.0Ah Lithium-ion Battery Packs (shared with mower)
- (1) 24V 2.5A Battery Charger (shared with mower)
- (1) Operator's Manual

WARNING

Before assembly, make sure that the blower is switched off and the battery is removed. If any parts are damaged or missing, do not operate this product until the parts are replaced. Failure to heed this warning so could result in serious personal injury.

Do not attempt to modify this product or create accessories not recommended for use with this product.

Any such alteration or modification is misuse and could result in a hazardous condition leading to possible serious personal injury. Always remove battery pack from your tool when you are assembling parts, making adjustments, cleaning, or when not in use. Removing battery pack will prevent accidental starting that could cause serious personal injury.

Never operate without the proper safety devices in place and working. Never operate with damaged safety devices. Failure to heed this warning can result in serious personal injury.

ASSEMBLY

ATTACHING THE BLOWER TUBE

1. Align the widest end of the blower tube with the front opening on the blower.
2. Slide the blower tube over the opening until it snaps onto the latch and the blower tube is secure in place.

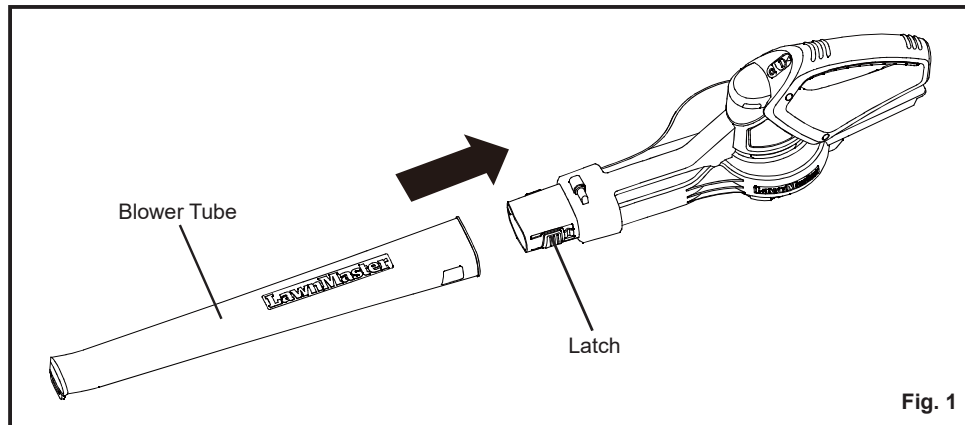

Fig. 1

INSTALLING / REMOVING THE BATTERY PACK

To install the battery pack:

1. Make sure the battery is fully charged.
2. Align the battery pack with the battery slot on the underside of the main handle, and then insert the battery pack into the handle (Fig. 2).
3. Push the battery pack until you hear a “click”.

To remove the battery pack:

1. Ensure the blower is switched off.
2. Press the release button on the battery pack. Grasp the blower firmly, and pull the battery pack out of the handle (Fig. 2).

NOTE: The battery pack fits into the bottom of handle snugly in order to prevent accidental dislodging. It may require a strong pull to remove it.

ASSEMBLY

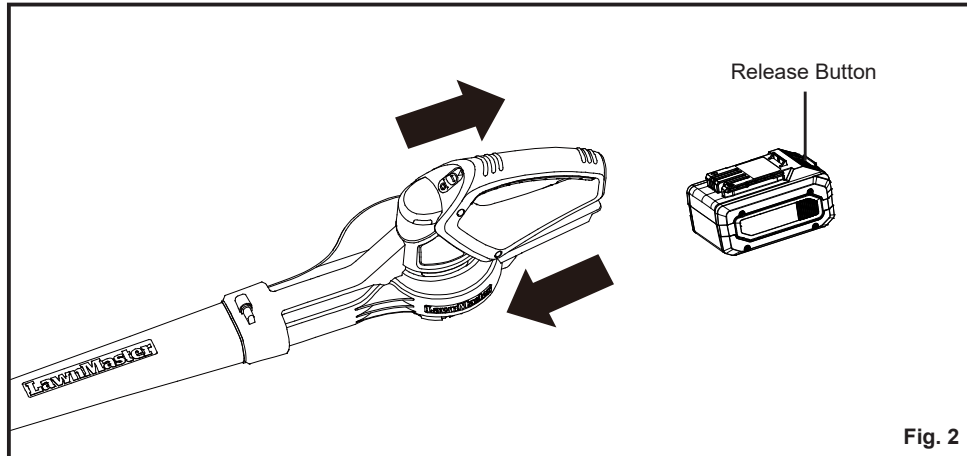

WARNING

Follow these instructions in order to avoid injury and to reduce the risk of electric shock or fire:

- Replace the battery pack or the charger immediately if the battery case or charger cord is damaged.
 - Verify that the switch is in the OFF position before inserting or removing the battery pack.
 - Verify that the battery pack is removed, and the switch is in the OFF position before inspecting, adjusting, or performing maintenance on any part of the blower.
-

BATTERY PACK AND CHARGER







BATTERY CHARGING

1. Use only with 24V LawnMaster® battery chargers. The battery charger supplied is specifically designed for the lithium-ion battery used in this tool.
2. Check the power voltage! Battery chargers operate on 120V.
3. The battery is charged between 40°F (4°C) and 104°F (40°C). This ensures an optimum battery service life.
4. Protect the battery from heat, from continuous exposure to sun, and keep away from radiation or other heat sources. Do not leave the battery in the tool in direct sunlight over long periods.
5. The battery is supplied partially charged. To ensure full capacity of the battery, charge the battery before using the tool for the first time. The lithium-ion battery can be charged at any time without reducing its service life. Interrupting the charging procedure does not affect the battery.

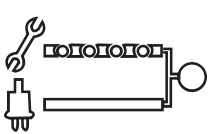
LED CHARGER STATUS

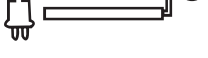
1. If the battery is not inserted into the charger, a **continuous red LED light** indicates that the charger is plugged into a power supply socket and is now ready to begin charging.
2. Charging: A **flashing green LED** on the charger indicates that the battery is charging normally.
3. Charged: **Continuous green LED** on the charger indicates that the battery is ready for use.

The indicator lights on the charger show the charger status:

SYMBOL	INDICATOR LIGHTS	STATUS
		Red, blinking
		Red, continuous
		Green, blinking
		Green, continuous

4. The intelligent charger ensures maximum battery life, because it measures the existing charge level of the battery and then charges with the required current and voltage. Charge battery fully before storage.
5. **Technical Issue: A flashing red LED** light on the charger indicates that battery pack has a charging problem or might be defective.
 - a) One possible condition is the battery temperature is not within the charging temperature range of 40°F (4°C) and 104°F (40°C). As soon as the permitted temperature is reached, the battery charger will automatically switch to charging.

BATTERY PACK AND CHARGER

- b) If the temperature range is correct and flashing red LED light continues, then remove and reinstall the battery pack. If the LED status repeats a second time, try to charge another identical battery. If the battery charges normally, dispose of the defective battery pack (see Environmental Safe Battery Disposal section).
 - c) If the flashing red light continues after installing the second battery (ensure the battery temperature is normal), the charger may be defective. Replace with a new one.
6. After continuous or repeated charging cycles without interruption, the charger may warm up. This is normal and does not indicate a technical defect of the battery charger.

BATTERY LED PANEL

1. The panel consists of 3 LEDs on the battery. Press and hold the button, then release it, the LEDs will show you the charge levels.
2. The battery's charge level can be checked either when the battery is attached on the charger/blower or removed from the charger/blower.

LEDs on Battery (Continuous lighting)	Battery Capacity
3 LEDs (inc 2 green)	Fully charged
2 LEDs (orange & red)	≥40%
1 LED (red only)	< 40%. Recharge required.

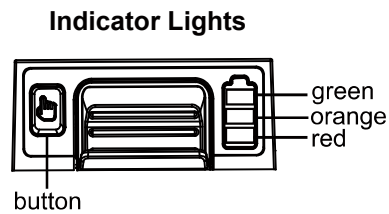

CHARGING THE BATTERY PACK

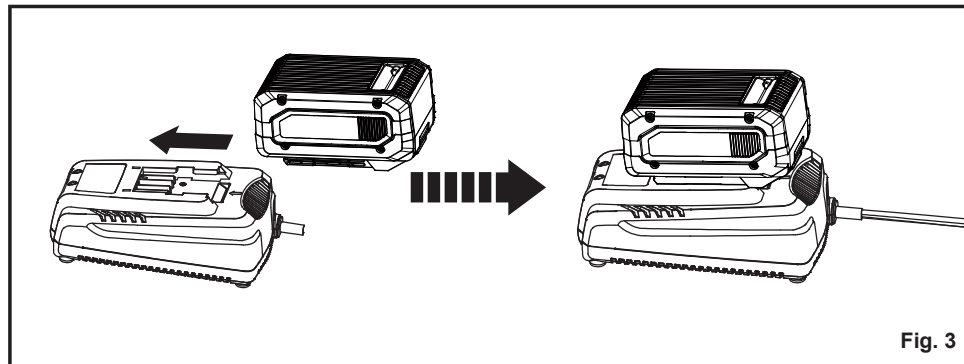

BATTERY PACK AND CHARGER

WARNING

If any part of the charger is missing or damaged, do not operate it! Replace the charger with a new one. Failure to heed this warning could result in possible serious injury.

Check the voltage! The voltage must comply with the information on the rating label.

1. Align the slot of the battery pack with the rail on the charger. Slide the battery onto the rail until the battery pack secures into place (Fig. 3).
2. Connect the charger to the power supply.
3. Allow sufficient charging time (see Specifications), and then disconnect the charger from the power supply.
4. Press the release button on the battery pack and remove it from the charger.

NOTE: It is normal for the battery pack and the charger to become warm (but not hot) during charging process. If the battery does not charge properly, check to make sure the electrical outlet is operational. **Always charge the battery before storage! To reduce risk of fire, never leave the battery connected with the charger for more than 24 hours!**

OPERATION

STARTING / STOPPING THE BLOWER

1. Make sure the power switch is in its off position, and the battery pack is installed properly.
2. To start the blower, place the power switch in the ON (I) position.
3. To stop the blower, place the power switch in the OFF (O) position.

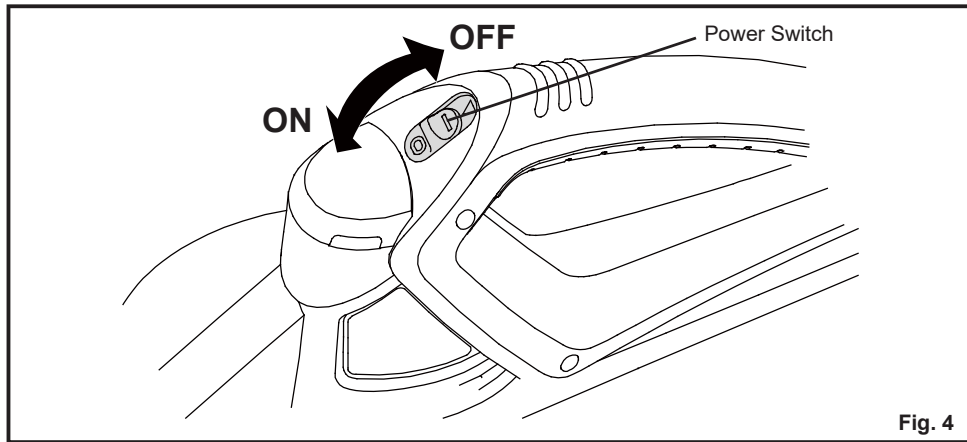

USING THE BLOWER

1. Blow debris or grass clippings off driveways, sidewalks, patios, parks, parking lots, etc.
2. Gather grass clippings, straw, or leaves into piles. Remove debris from corners, around joints, and between bricks.

NOTE: Your Lawnmaster® blower is designed to blow and clean hard surfaces, such as patios, driveways, decks, garages, and sidewalks.

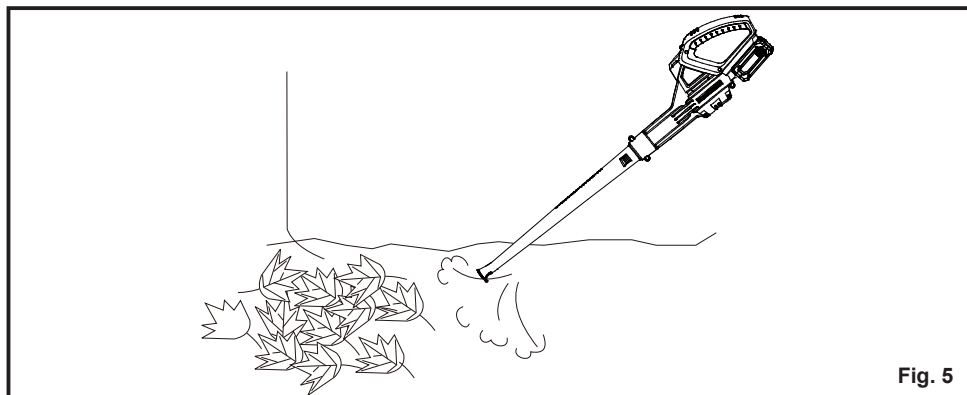

MAINTENANCE

WARNING

When servicing, use only identical replacement parts. Use of any other parts may create a hazard or cause product damage.

WARNING

Always wear eye protection with side shields marked to comply with ANSI Z87.1, along with hearing protection. Failure to do so could result in objects being thrown into your eyes, resulting in possible serious injury.

WARNING

To avoid serious personal injury, always remove the battery pack from the tool when cleaning or performing any maintenance.

GENERAL MAINTENANCE

1. Remove the battery pack.
2. Brush or blow dust and debris out of the air vents using compressed air or a vacuum. Keep the air vents free of obstructions, sawdust, and wood chips. Do not spray, wash, or immerse the air vents in water.
3. Wipe off the housing and the plastic components using a moist, soft cloth. Do not use strong solvents or detergents on the plastic housing or plastic components. Certain household cleaners may cause damage, and may cause a shock hazard.

BATTERY PACK MAINTENANCE

1. Fully charge the battery before placing in storage.
2. Recharge the battery pack whenever there is a noticeable reduction in the performance. Do not allow the battery pack to become completely discharged.
3. Do not recharge a battery pack that is already fully charged. Overcharging shortens battery life.
4. Once the battery pack is fully charged, remove the battery from the charger and disconnect charger from the outlet.
5. Do not store the battery pack on the tool or on the charger.
6. If the battery pack is hot, allow it to cool down before recharging.

MAINTENANCE

CHARGER MAINTENANCE

1. Keep the charger clean and clear of debris. Do not allow foreign material into the recessed cavity or on the contacts. Wipe with a dry cloth. Do not use solvents, water, or place in wet conditions.
2. Always unplug the charger when the battery pack is not installed on the charger.
3. Do not store the charger in excessive heat. Do not use in direct sunlight.
4. Disconnect the charger from the AC power outlet when not in use and once battery has reached a full charge.

ENVIRONMENTALLY SAFE BATTERY DISPOSAL



The following toxic and corrosive materials are in the batteries used in this battery pack:
lithium-ion, a toxic material.

WARNING

All toxic materials must be disposed of in a specific manner to prevent contamination of the environment. Before disposing of damaged or worn-out lithium-ion battery packs, contact your local waste disposal agency, or the local Environment Protection Agency for information and specific instructions.

WARNING

If the battery pack cracks or breaks, with or without leaks, do not recharge it and do not use. Dispose of it and replace with a new battery pack.

DO NOT ATTEMPT TO REPAIR IT!

To avoid injury and risk of fire, explosion, or electric shock, and to avoid damage to the environment:

- Cover the battery terminals with heavy-duty adhesive tape.
- **DO NOT** attempt to remove or destroy any of the battery pack components.
- **DO NOT** attempt to open the battery pack.
- If a leak develops, the released electrolytes are corrosive and toxic. **DO NOT** get the solution in the eyes or on skin, and do not swallow it.
- **DO NOT** place damaged or defective batteries in your regular household trash.
- **DO NOT** incinerate.
- **DO NOT** place batteries where they will become part of any waste landfill or municipal solid waste stream.
- Take batteries to a certified recycling or disposal center.

TROUBLESHOOTING

Suspected malfunctions are often due to causes that the user can fix themselves. Therefore, check the product using this section. In most cases the problem can be solved quickly.

WARNING

Only perform the steps described within these instructions!

All further inspection, maintenance and repair work must be performed by an authorized service center or a similarly qualified specialist if you cannot solve the problem yourself!

PROBLEM	POSSIBLE CAUSE	SOLUTION
Motor fails to start when power switch is turned on.	The battery is not secure.	To secure the battery pack, make sure the latches on the bottom of the battery pack snap into place.
	The battery is not charged.	Remove and charge the battery pack.
	Defective power switch or defective battery.	Call Customer Service for assistance (Toll free number 866-384-8432).
The blower will not blow.	The tube is blocked.	Clear the blockage.
Charger 2Hz red LED light flashing.	Battery pack is too hot.	Allow the battery pack to reach normal temperature. Charging will begin when battery pack returns to normal temperature.

For more status of the indicator lights on battery & charger, refer to page 15-16.

LAWNMASTER® WARRANTY

We take pride in producing a high quality, durable product. This LawnMaster® product carries a limited two (2) year warranty against defects in workmanship and materials from date of purchase under normal household use. If product is to be used for commercial, industrial or rental use, a 30 day limited warranty will apply. **Batteries carry a one-year warranty against defects in workmanship and materials.** Batteries must be charged in accordance with the operator's manual directions and regulations in order to be valid. Warranty does not apply to defects due to direct or indirect abuse, negligence, misuse, accidents, repairs or alterations and lack of maintenance. Please keep your receipt/packing list as proof of purchase. This warranty gives you specific legal rights, and you may have other rights, which vary from state to state. For product service call Customer Service at 1-866-384-8432.

Items not covered by warranty :

1. Any part that has become inoperative due to misuse, commercial use, abuse, neglect, accident, improper maintenance, or alteration;
2. The unit, if it has not been operated and/or maintained in accordance with the owner's manual;
3. Normal wear, except as noted below;
4. Routine maintenance items such as lubricants;
5. Normal deterioration of the exterior finish due to use or exposure;

Transportation Charges : Transportation charges for the movement of any power equipment unit or attachment are the responsibility of the purchaser. It is the purchaser's responsibility to pay transportation charges for any part submitted for replacement under this warranty unless such return is requested in writing by LawnMaster®.

SAVE YOUR RECEIPTS. THIS WARRANTY IS VOID WITHOUT THEM.

EXPLODED VIEW

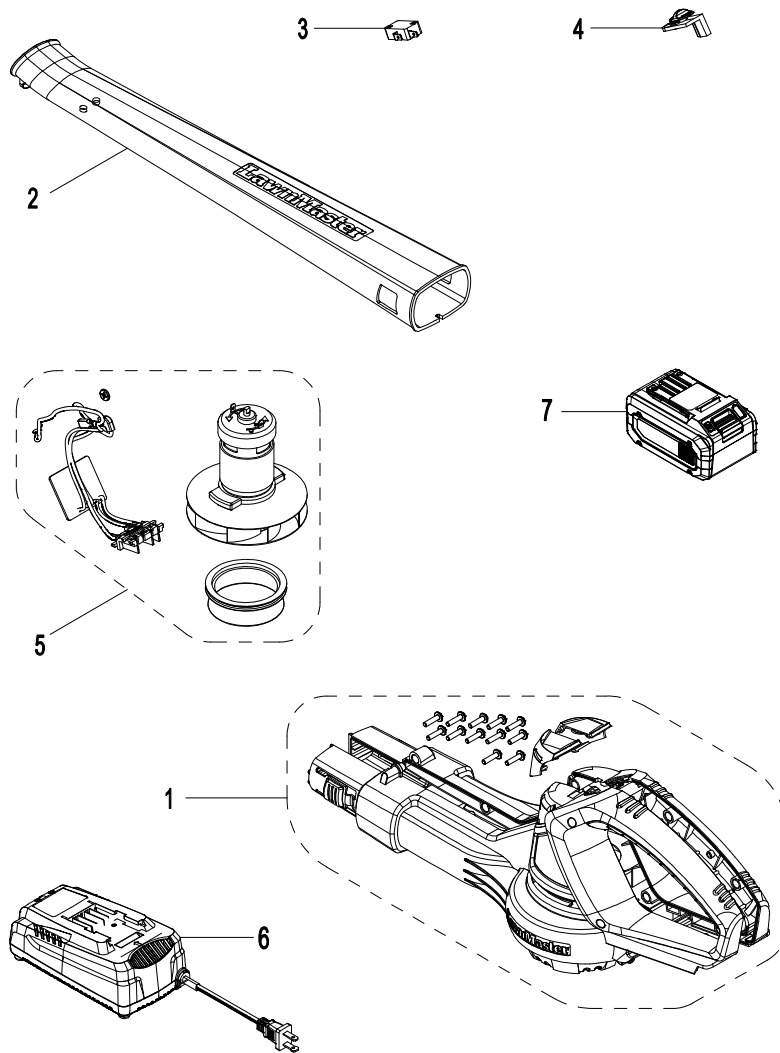

PARTS LIST

Key Number	Part Number	Description	Quantity
1		Motor Housing Assembly	1
2	211079108	Blower Tube	1
3		Micro Switch	1
4		Switch Push Button	1
5		Motor Assembly	1
6	241003111	Charger	1
7	211070122	Battery	1

Replacement parts highlighted in grey are available for after sales purchase. Replacement of repair or internal parts should only be done by a qualified service professional. Please contact your authorized service dealer or Customer Service at 866-384-8432.

